

OBC5100™

by On-Board Communications, Inc.



***OBC5100
W/ Starter Interrupt &
Optional PTO Input
General Installation Guide***

Proprietary and Confidential

Table of Contents

OBC5100™ Installation Kit Contents	4
Introduction to GPS	6
Safety Statement.....	6
Additional Support.....	6
Tool List.....	7
Selecting the Mounting Location for the OBC5100	8
Selecting the Cellular / GPS Antenna Location.....	8
Optional PTO Input	9
Powering the Unit for the First Time.....	9
OBC5100™ Wiring Diagram	10
Congratulations!	11
INSTALLATION WIRING DIAGRAM	12
TROUBLESHOOTING GUIDE.....	13

Proprietary and Confidential

OBC5100™

by On-Board Communications, Inc.



Thank you for selecting the OBC5100™ Wireless Tracking, Monitoring and Remote Control, Vehicle Management Solution. The OBC5100™ is designed to provide efficient, affordable, nationwide vehicle tracking.

This guide describes how to install, activate and use your OBC5100™ unit. Following the instructions in this guide will enable you to get your unit operating quickly and easily. In the event that you require additional assistance, please contact customer support via e-mail at support@obccom.com or contact us at the address or contact number below:

On-Board Communications, Inc.
Attn: Customer Support
12720 Hillcrest Road
Dallas, TX 75230
877-340-0300 ext. 290

CAUTION: On-Board Communications, Inc. is not responsible for damages to any vehicle due to OBC5100™ unit installation.

Notes:

- **Failure to install the OBC5100™ unit in accordance with these instructions may result in damage to the vehicle and may void the unit's warranty.**
- **Read all instructions before attempting installation.**

Proprietary and Confidential

OBC5100™

by On-Board Communications, Inc.



OBC5100™ Installation Kit Contents



OBC5100™

White tape must face skyward upon install



Cellular & GPS Antenna Combined & 3ft. Cable

Proprietary and Confidential



Power Cable

Electrical Connections / Mounting Kit:

- 3 Small Cable Ties
- 1 #10 Ring Terminal
- 2 Posi-Tap™ Connectors
- 2 128" Female Quick-disconnect
- 2 Mini Fuse-Tap Connectors
- 1 2" x 1 ½" Velcro™ Self-Adhesive Strip
- 2 Alcohol Prep Swabs

Antenna Mounting Kit:

- 1 ½" x 1" Velcro Self Adhesive Strip

Proprietary and Confidential

Introduction to GPS

Satellites are in a 12-hour orbit at 12,000 miles above the earth. There are 24 satellites in the system and generally there are at least 5 satellites orbiting overhead at any one time. This antenna must be positioned to receive signals from these satellites. The antenna location must be selected carefully so that the antenna can receive the satellite signals. The standard GPS antenna is designed to be located inside the vehicle. The ideal location is in a place that allows line of sight reception from the GPS satellites in orbit above. The satellite signals will pass through glass. Both the radio transceiver antenna and GPS antenna are designed to be mounted inside the vehicle, (not exposed to the outside weather).

Safety Statement

This guide covers the installation of the OBC5100™ to ensure a safe and functional install of the unit by either a professional or novice installer.

- **Before attempting to add anything electrical to your vehicle, refer to the Owner's Manual for additional information.**
- **Always disconnect the vehicle battery while installing this or any other automotive electronic product.**
- **Make sure the unit and all associated cables are securely mounted and do not impede any of the vehicle's controls. Do not mount the unit near brake and gas pedals.**
- Use care when routing the unit's cables. Route the cables where they will be protected. Use commonly accepted install practices for after-market automotive electronic devices. Here are three acceptable methods of making a wire connection:
 - Soldering your connections (recommended)
 - Crimp connectors (with the use of the proper crimping tool)
 - Posi-Tap™ Connectors (no tools required)

Regardless of the method you choose, ensure that the connection is mechanically sound and properly insulated. Use high quality electrical tape and shrink tubing where necessary.

This product is connected directly to the vehicle's 12-volt system. There is no on-off switch on the unit. The installed device operates 24 hours a day and must be energized to log vehicle events or send data as required by anyone using the service.

Additional Support

- Over the phone Support is available.

Proprietary and Confidential

Tool List

- Power drill AC/DC (Cordless recommended)
- Magnetic bit holder that houses Phillips and flat-head bits
- Wire stripper and cutters
- Crimpers for insulated connectors
- Electronic voltage meter (Digital display recommended)
- Tools to disconnect and reconnect vehicle battery (Crescent wrench, open end wrenches, etc.)
- Tools to remove internal vehicle trim (Panel poppers, sockets, ratchet, screwdrivers, torx bits, hex bits, etc.)
- Ring terminal connectors (For grounding wire)
- Self tapping screws (Various sizes)
- Star washers for grounding (Strongly recommended)
- Electrical tape (Black)
- Wire 20 gauge
- Velcro and/or double sided tape
- Wire ties (Various sizes)
- Soldering iron & solder

Using Your Digital Multi Meter

On-Board Technical Support hears more and more often about damaged computers and airbag systems as a result of probing with a test light. Not all air bag wires are in yellow tubing, and not all transistorized outputs can light a test light bulb without shorting out! The best solution, as it has always been, is a good digital multi meter.

How to Find (+) 12VDC Ignition with Your Multi Meter

1. Set your meter to DCV or DC voltage (12VDC or 20VDC is fine)
2. Attach the (-) probe of the meter to chassis ground.
3. Probe the wire you suspect of being the ignition wire. The steering column is an excellent place to find this wire. Your meter should read (+) 0V.
4. Turn the ignition key to the "ON" position. If your meter reads (+)12VDC, go to the next step. If it doesn't, probe another wire.
5. Now turn the key to the start position. The meter display should stay steady (+) 12V, not dropping by more than a few tenths of a volt. If it drops close to or all the way to zero, go back to step 3. If it stays steady at (+) 12VDC you have the ignition wire.

Proprietary and Confidential

OBC5100™

by On-Board Communications, Inc.



Selecting the Mounting Location for the OBC5100

The OBC5100™ and the cables that connect to it must be mounted so it will:

- Not be exposed to damage from people or objects
- Not impede any of the vehicle's operational systems such as steering, brake or gas pedals

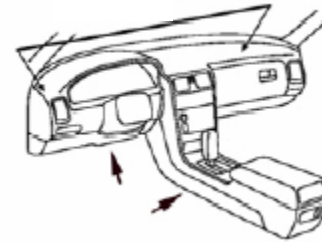

In addition, the OBC5100™ unit itself must not be exposed to direct sunlight or excessive heat generated by the vehicle's operation.

A flat surface is recommended for the unit's placement. The installation Velcro is designed to hold the unit in place; however additional mounting items may be needed to help secure the unit if a flat surface is not available. Do not hang the unit from the installation Velcro without additional mounting hardware as vibration from the vehicle's use will cause the unit to fall.

Some examples of mounting locations include: under the dash above the knee bolster, under the center console, behind the glove compartment, and in the trunk.

Selecting the Cellular / GPS Antenna Location

The OBC5100 combines the Cellular and GPS antennas into one antenna package. The antenna does not require a ground plane to function properly.

THE ANTENNA MUST BE MOUNTED FLAT WITH THE "WHITE 3M TAPE" FACING SKYWARD. The ideal location is under a non metallic dashboard. It can be placed under the dash pad as long as the pad or covering is not metallic or a barrier to the GPS satellite signals. If the antenna is placed under the dash, the 3M tape can be used to secure or hang the antenna from the dash. Otherwise the small piece of Velcro can be placed on the back side of the antenna and the antenna stuck to a flat surface with the 3M tape facing skyward.

If the vehicle window has a solid dark coating around the edge, do not place the GPS antenna behind the coating. The GPS signals will travel through the clear glass but will be reduced if the window has any metallic coating or tint applied.

The GPS antenna will work best if it has a clear view to the sky and as much of the horizon as possible. Any metallic objects between the antenna and the satellites will degrade the signal and reduce the overall performance.

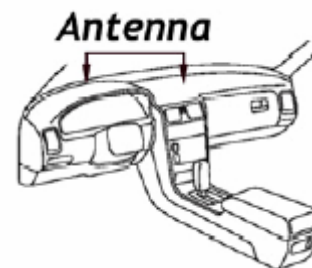

Proprietary and Confidential

OBC5100™

by On-Board Communications, Inc.



Locating Vehicle Power

Connect the red lead to the +12VDC vehicle power. The power cable can be shortened if needed. Connect the black lead to the vehicle chassis (ground).

See Attached wiring diagram at the end of this installation guide for connection of the Starter/Interrupt circuit or the optional PTO input.

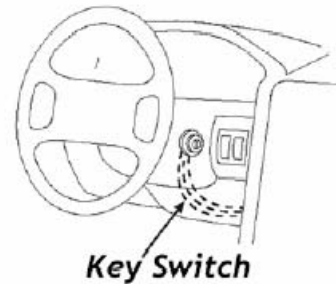

***Improper connection could result in numerous "Reboot" notifications, and increased usage on monthly billing.**

Optional PTO Input

If equipped with the proper software configuration, the OBC5100 can be wired to a PTO (Power Take-Off) circuit via the white wire from the starter interrupt power harness. When the PTO wire is grounded – the unit will report an OFF status. When the PTO wire goes high (+12V MAX) – the unit will report an ON status. An icon will appear next to the vehicle on the web application showing an ON/OFF status. There is also a report which can be compiled from the web application that will also show the amount of usage.

Powering the Unit for the First Time

After you have wired the power harness to the vehicle, connect the dual Cellular and GPS antenna connections to the OBC5100 matching the color of the connectors on the cable to the appropriate connectors on the unit (i.e – silver to silver and gold to gold). Then connect the power harness cable to the OBC5100™. Once the power harness cable is attached the Orange Cellular LED (closest to the power connection) will flash once. After approximately 1 to 2 minutes the light will come on and glow steadily indicating the unit has cellular coverage. The Yellow GPS LED (closest to the edge of the case) will not light until it locks onto the GPS signals. **Please note – the Antenna must have a clear view of the sky and not be blocked by any metal in order for the unit to lock onto the GPS signals. When installing the unit for the first time – it may take as long as 15 minutes for the unit to acquire a GPS lock. This delay is due to the unit searching for the satellites.** When it locks on, the LED glow steadily. The unit is now functioning properly.

Proprietary and Confidential

OBC5100™ Wiring Diagram

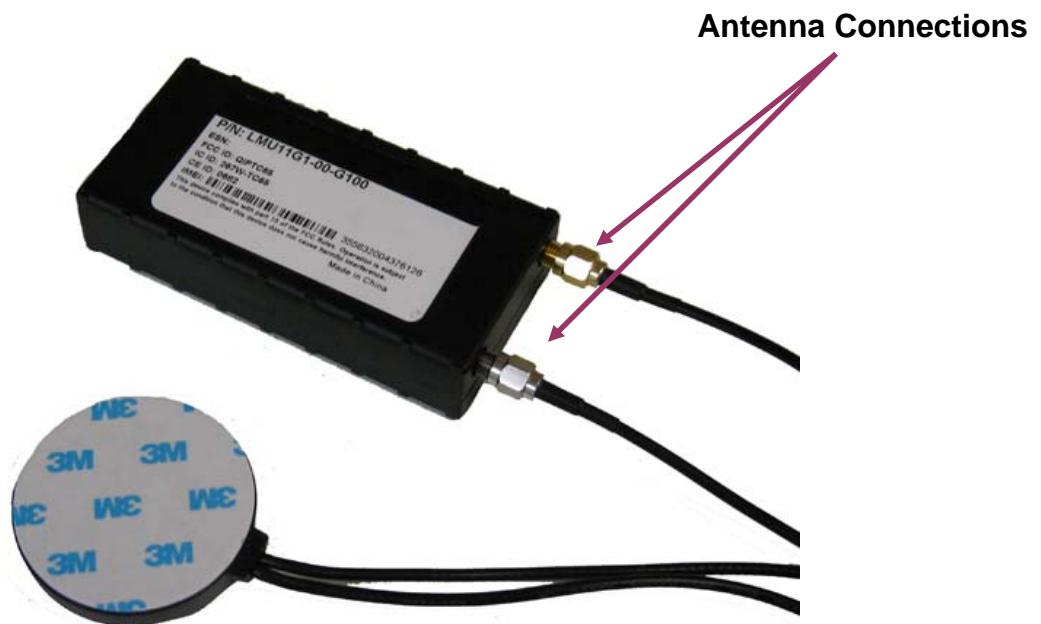
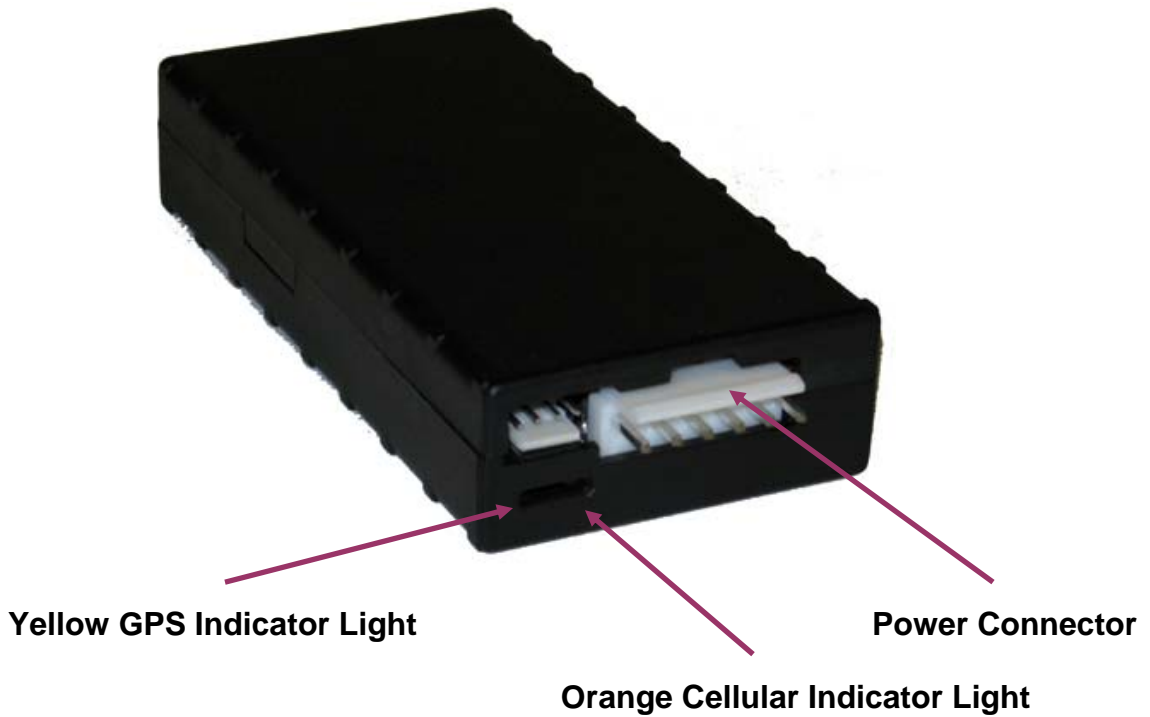

Unit with Antenna Connected

Proprietary and Confidential

OBC5100™

by On-Board Communications, Inc.



Congratulations!

You have just installed the OBC5100™ Internet based vehicle location system.

Please record the following information:

- **ESN ID # (located on the back of the OBC5100™- This is the 10 digit number located next to the words "ESN")**

Now that the unit is installed, here is how to use the system. Turn on your computer and log on to the Internet using your standard Internet browser. Go to the FleetTraks™ login page at www.fleettraks.com. Enter the customer login id and password and click the login button.

Proprietary and Confidential

INSTALLATION WIRING DIAGRAM

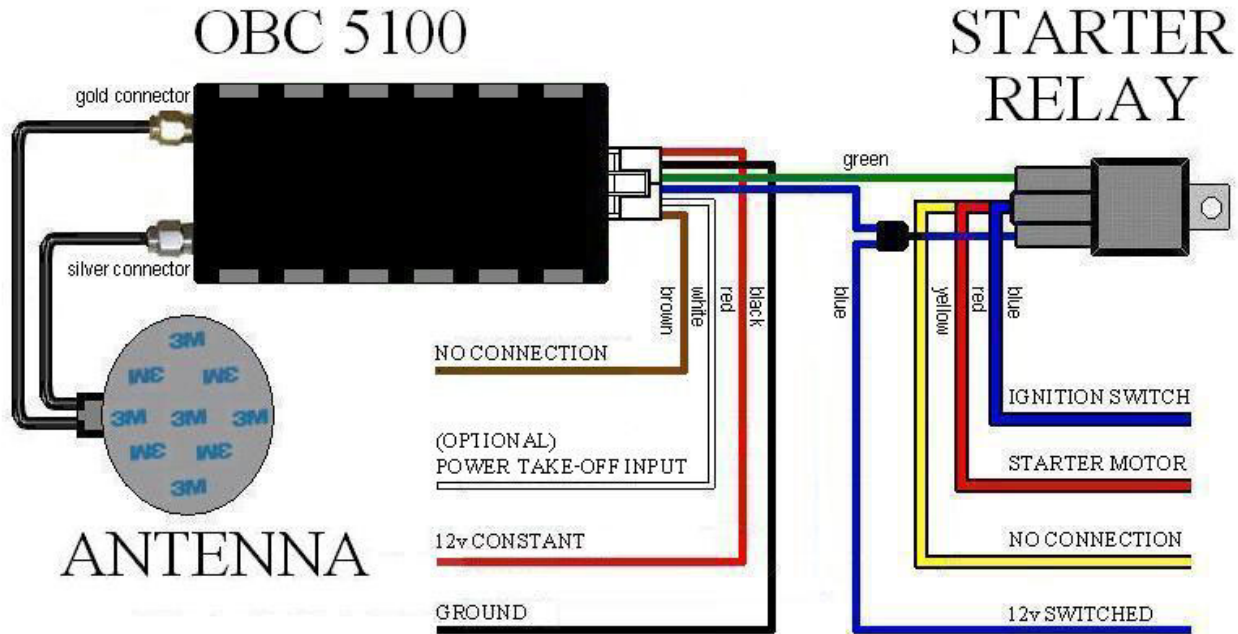

Proprietary and Confidential

TROUBLESHOOTING GUIDE

SYMPTON	PROBABLE CAUSE	SOLUTION
All LED's Dark	Lack of Power	Check to make sure +12VDC power is applied to the power leads. Directly applying a voltage over +24VDC to the unit may cause damage.
Cellular LED does not light	Unit is trying to locate the cellular network	Upon power being applied, the unit may take up to 2 minutes to acquire a cellular lock.
	Coverage Issue	If the unit does not acquire a cellular lock within five minutes of power being applied – there may be a coverage issue. Although most of the US has coverage, there are a few locations that do not. Please contact On-Board's technical support line.
GPS LED does not light <u>Applicable only if optional GPS antenna is installed</u>	Insufficient time to achieve a lock on the GPS satellite Signals	Upon power being applied, the unit may take up to 15 minutes to acquire a GPS lock.
	Coverage Issue due to: A) Poor Antenna Connection B) Blockage	Ensure the GPS antenna is securely attached to the unit Ensure the GPS antenna has a clear view of the sky and the word "GPS" on the antenna is facing up. Ensure the GPS antenna is not covered by any metallic or conductive materials Ensure the vehicle is outdoors and away from tall buildings which will block the GPS satellite signals.
Engine Hours are not registering properly on the web site.	Unit has not been synced with the engine hour's meter.	The OBC5100™ may be set up to show engine or run hours that match the engine hour meter on the equipment. To sync the unit, an off-set must be added to the ServiceTraks™ unit detail page.
	Blue (Switched Power) lead is not hooked up correctly	The blue (Switched Power) lead must be hooked up to the item you are trying to track. I.e. Ignition On or an engine hour meter. In the case of it being hooked to the ignition wire – this lead will show a voltage when the key is on and nothing when the key is off. The information from the unit will show the amount of time the ignition key was turned on – whether the engine was running or not.
PTO does not record properly	Unit may not be configured with the correct software for this feature to work	Contact On-Board Communications for proper software version
	Icon does not appear on the web application.	The PTO feature must be enabled on the web application in order for the icons to appear

Proprietary and Confidential